

NOTES

1. Do not scale from this drawing. If in doubt ask.
2. Contractor to check all dimensions on site prior to the commencement of works and report any discrepancies to the Architect immediately.
3. To be read in conjunction with all other drawings, bills and specification documents.
4. Cross refer to structural engineers design for all structural information.

END/ MID TERRACE MEWS HOUSE
3 Bedroom House
GIA 100.63m² - 1083 sq.ft.

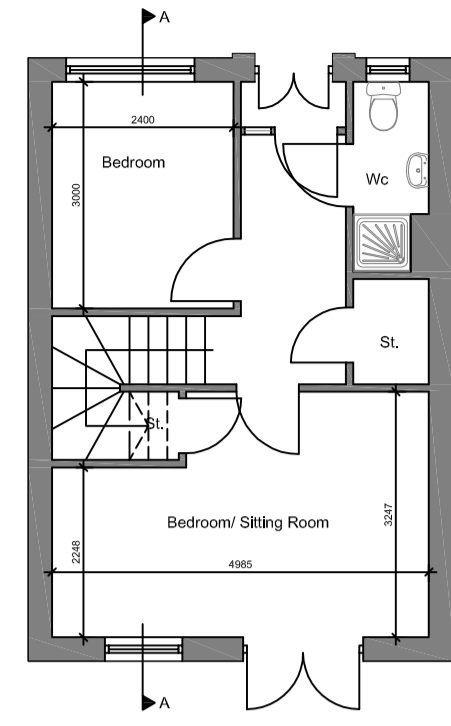

Ground Floor Plan

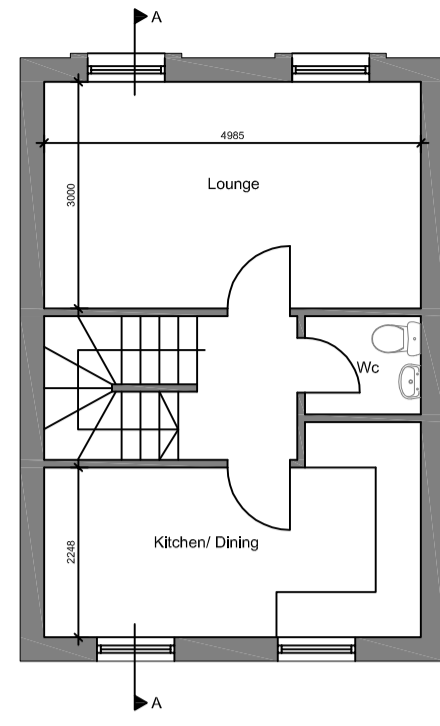

First Floor Plan

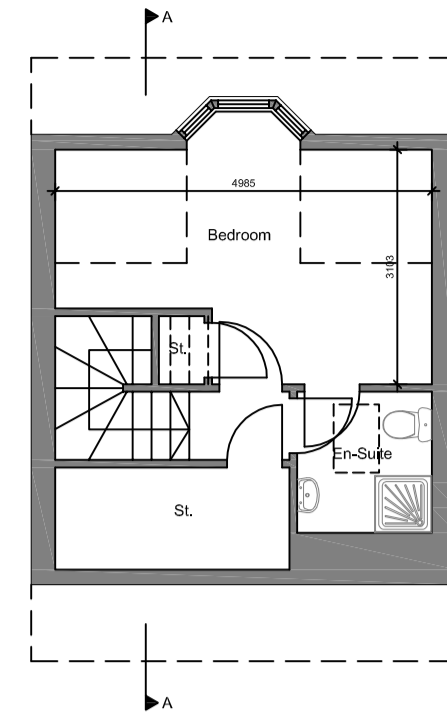

Second Floor Plan

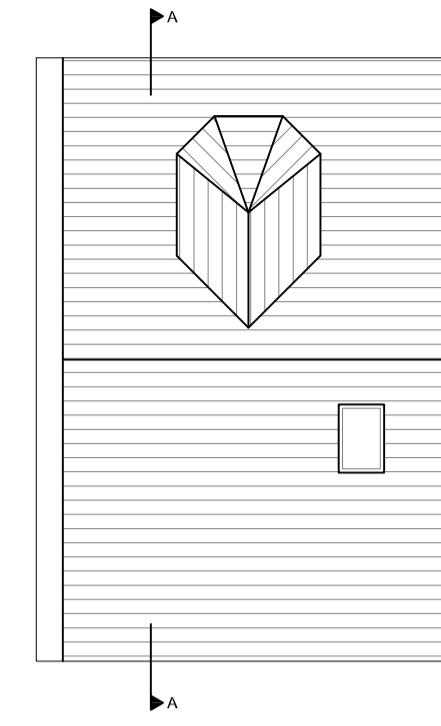

Roof Plan

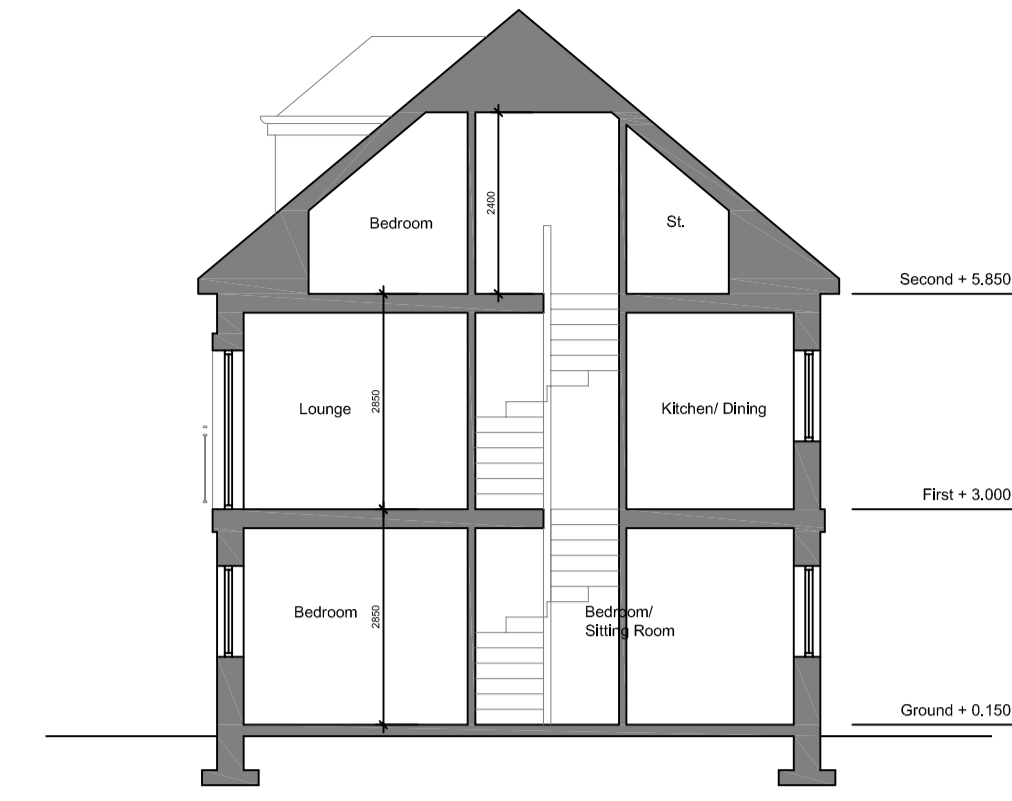

Section

CORNER MEWS HOUSE - Plots 74 & 83
4 Bedroom House
GIA 141.15m² - 1519 sq.ft.

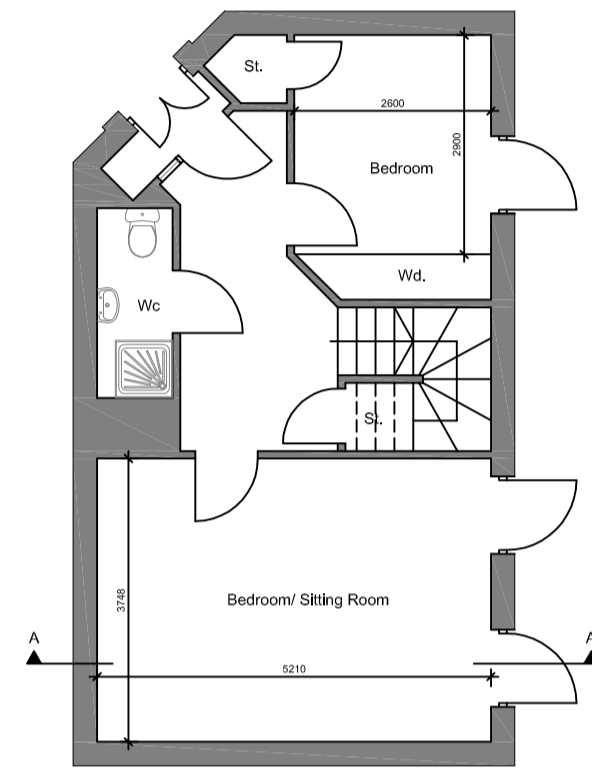

Ground Floor Plan

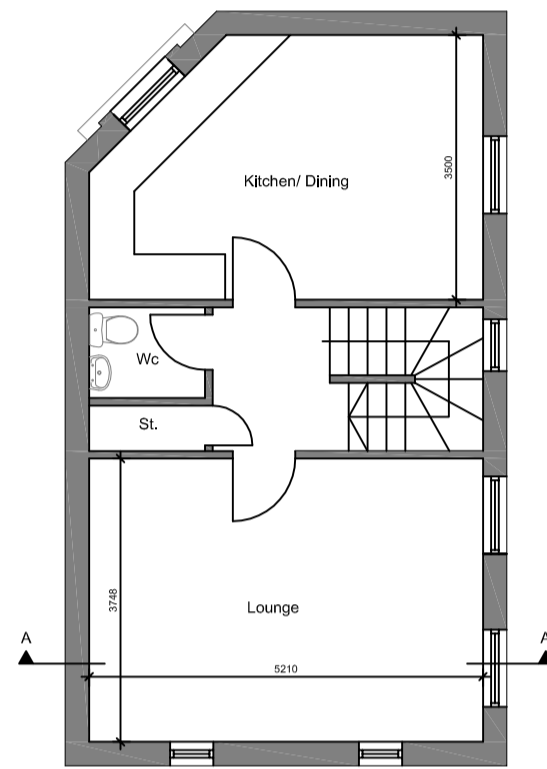

First Floor Plan

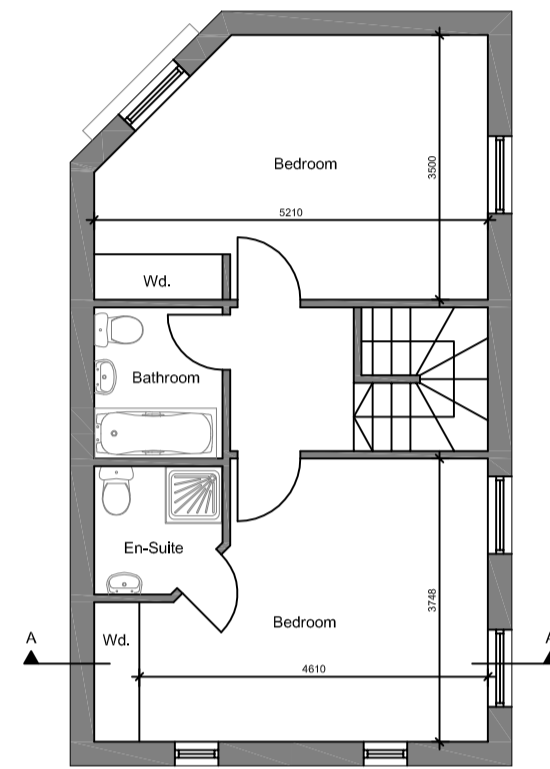

Second Floor Plan

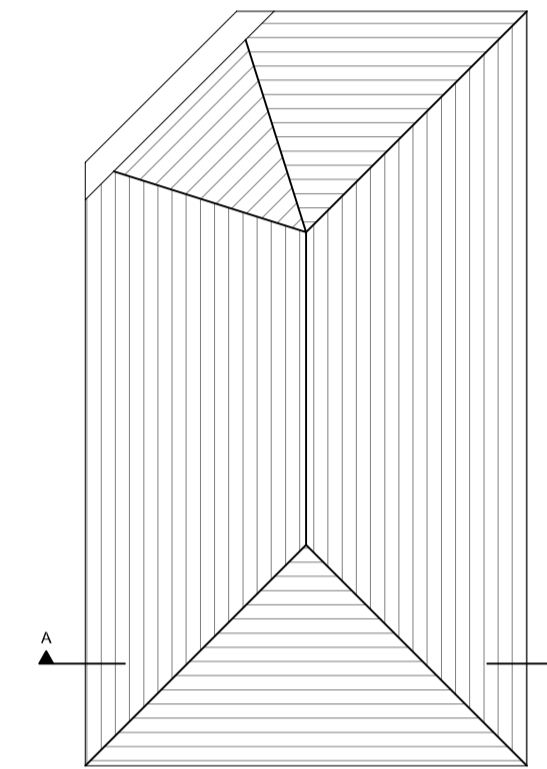

Roof Plan

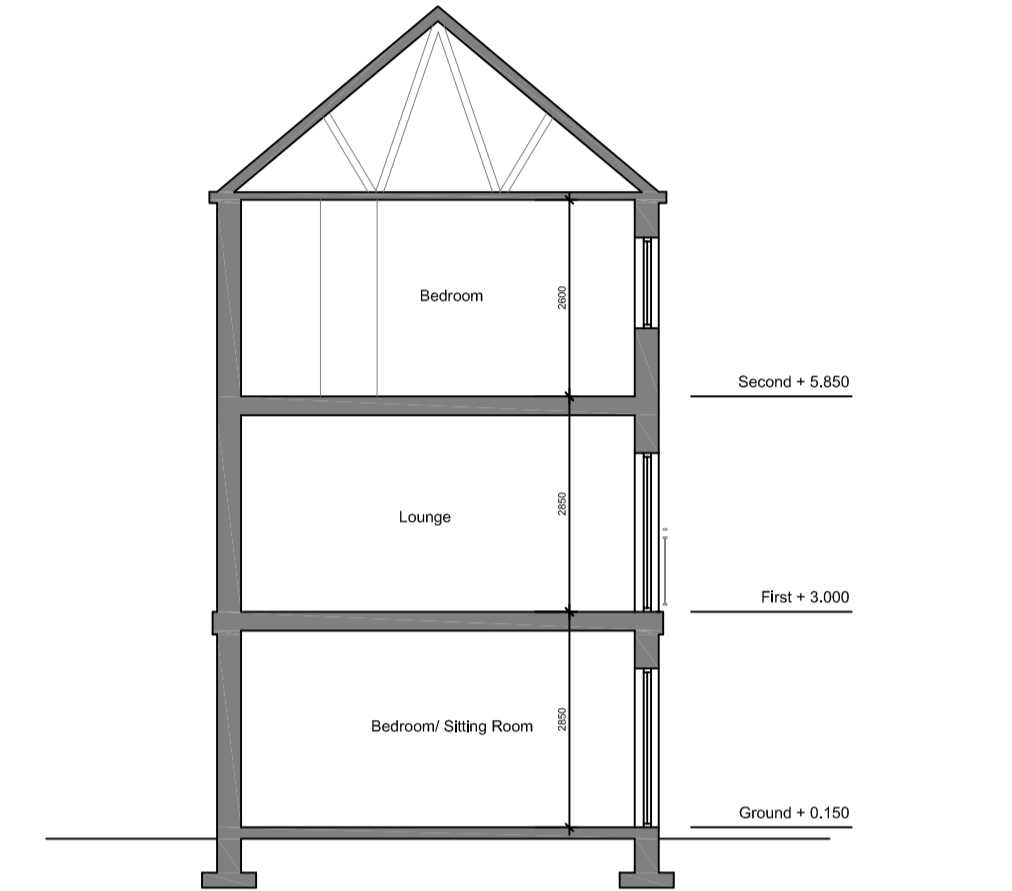

Section

END TERRACE MEWS HOUSE - Plots 78 & 79
4 Bedroom House
GIA 124.03m² - 1344 sq.ft.

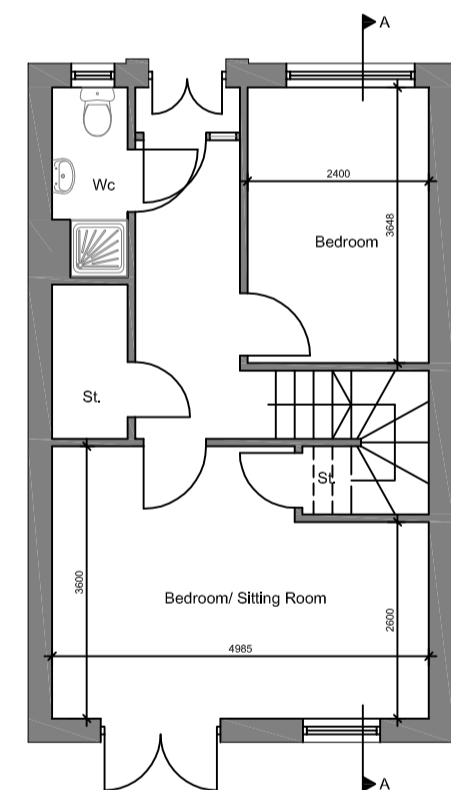

Ground Floor Plan

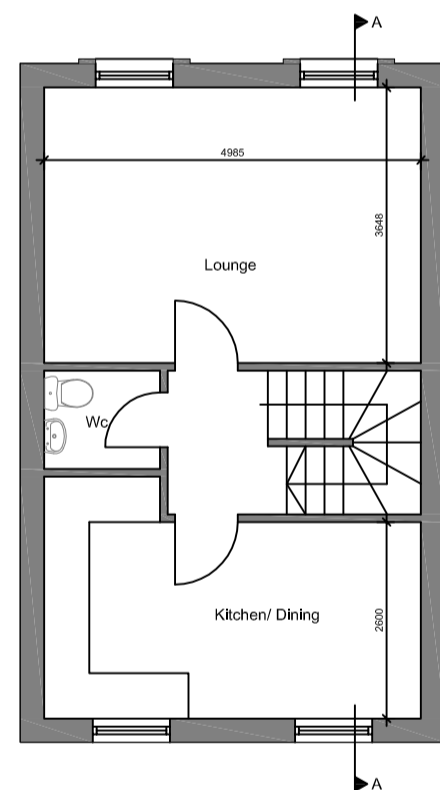

First Floor Plan

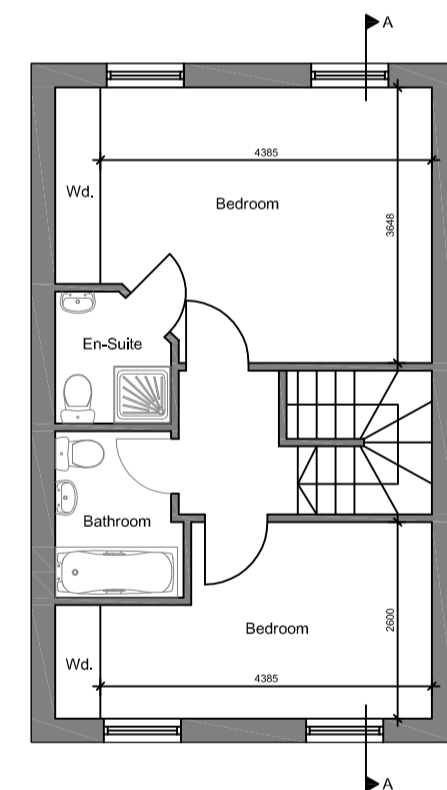

Second Floor Plan

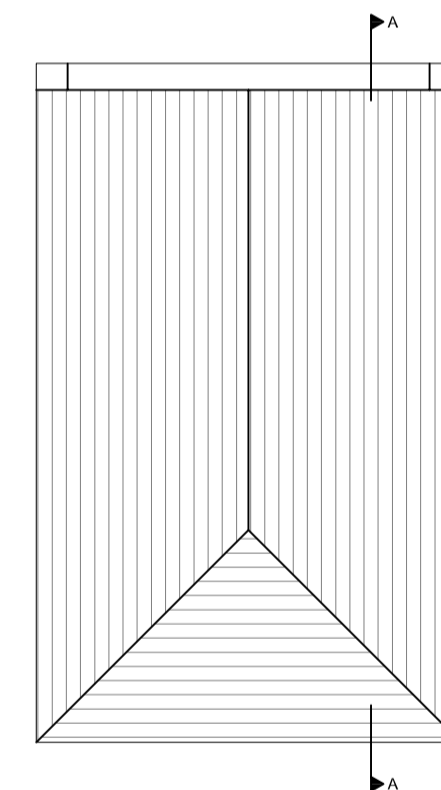

Roof Plan

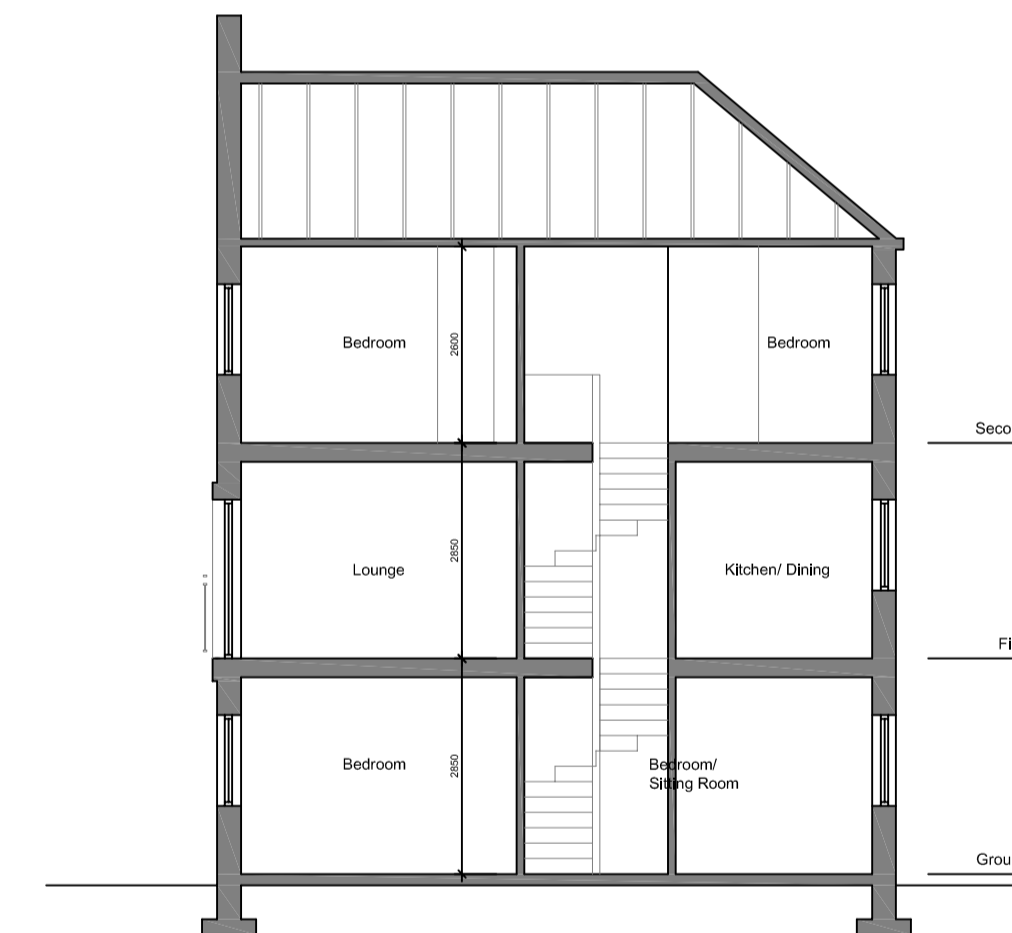

Section

DETACHED MEWS HOUSE - Plot 90
4 Bedroom House
GIA 160.08m² - 1723 sq.ft.

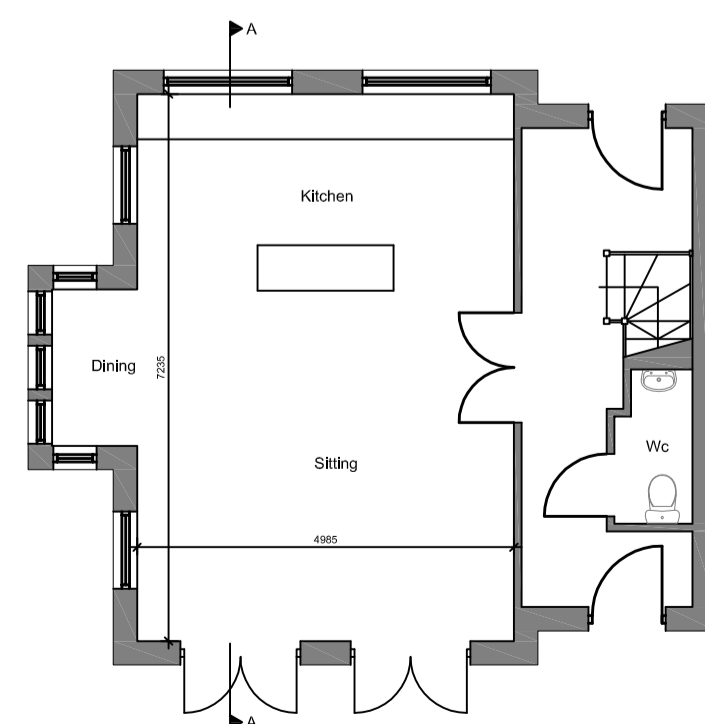

Ground Floor Plan

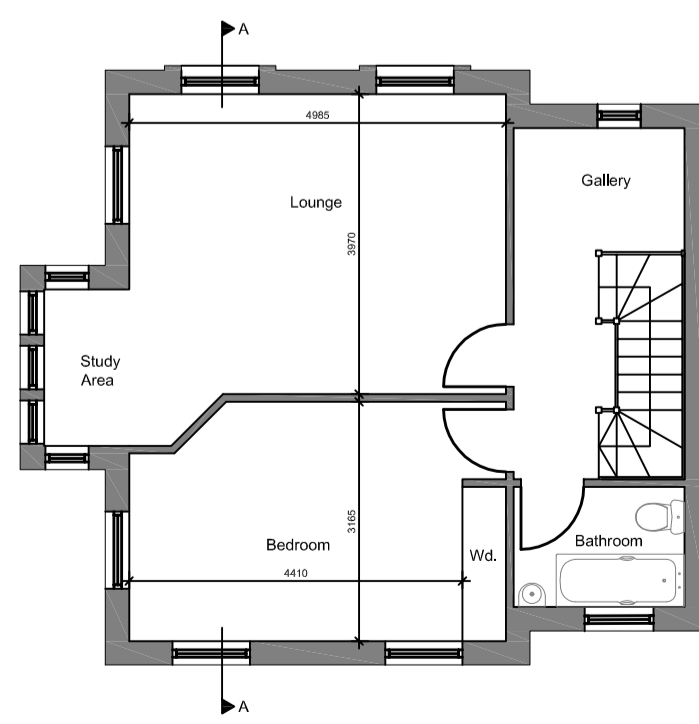

First Floor Plan

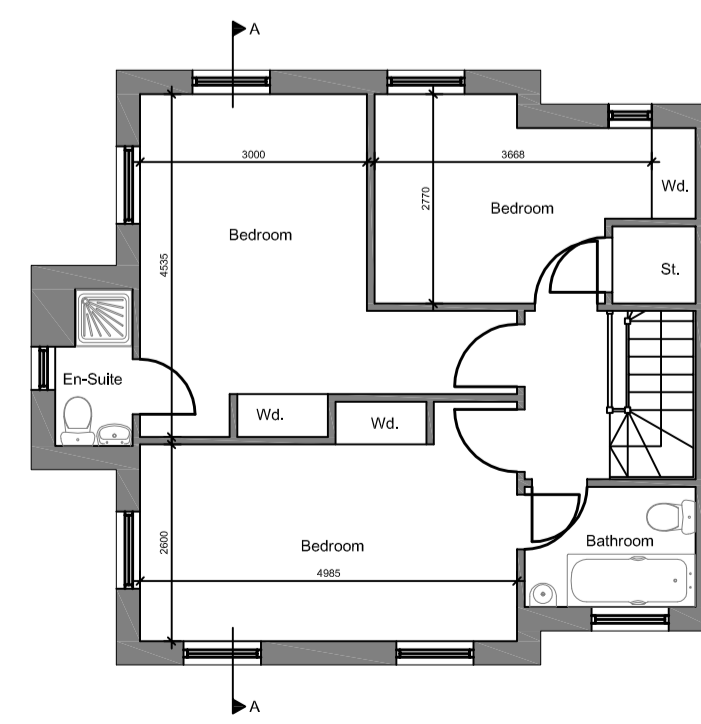

Second Floor Plan

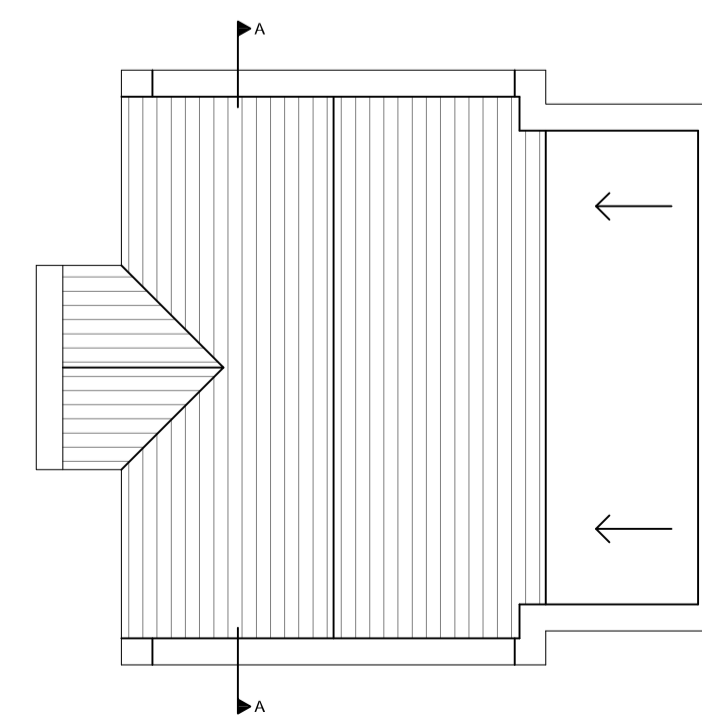

Roof Plan

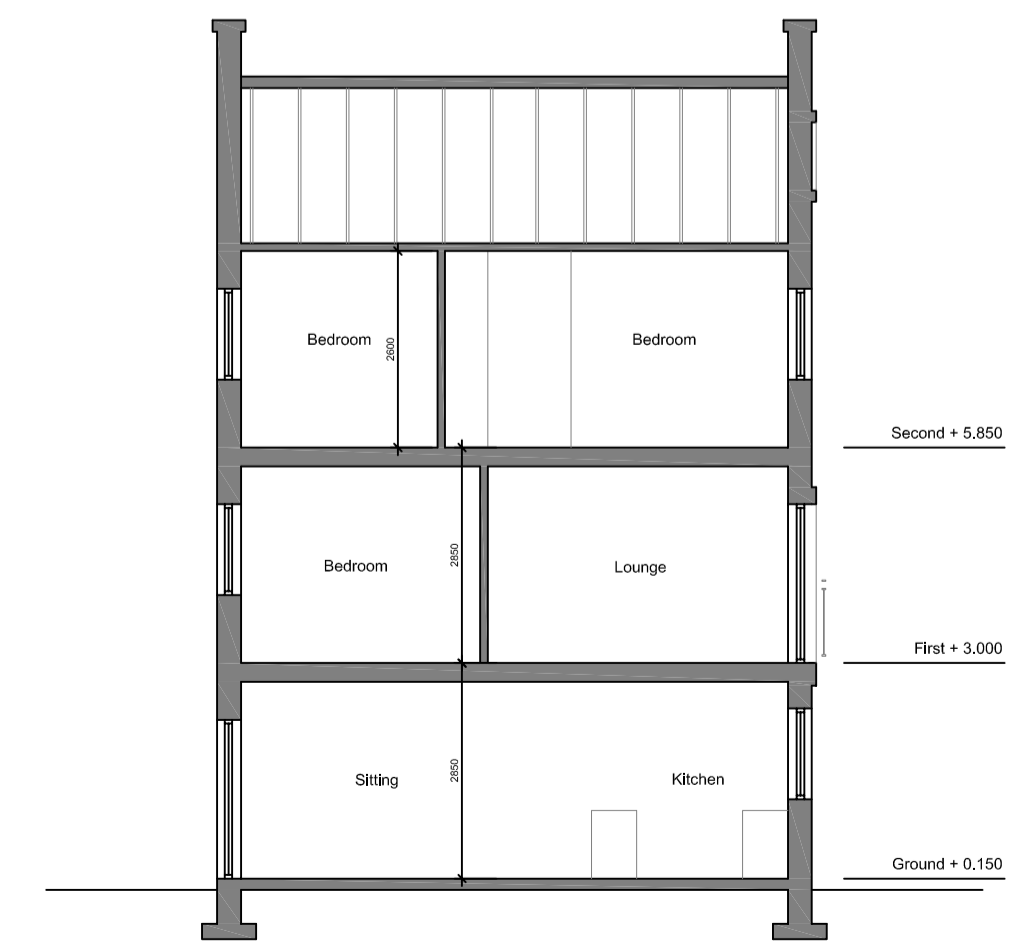

Section

rev.	date	description
A	06.12	Planning Update

	13 Newton Place Glasgow G3 7PR
New City Vision Our vision. Your future	t: 0141 353 2010 f: 0141 353 2442 e: info@newcityvision.co.uk www.newcityvision.co.uk
Project	CLOUSTON STREET
Drawing	Mews House Plans
Scale	1:100@A1
Package	
Date	30.04.12
Development	
Job No.	0059
Drawing Number	AL (0) 300
Revision	A
Status	Planning